

BELCO

PRESERVATIVE TREATED XT PRODUCTS

Installation Instructions



Installing XT Trim

Congratulations on selecting XT Trim, the ultimate in natural wood, treated trim products for your project! This manual covers installation instructions for both XT TRIM and XT POST. Failure to install XT products in accordance with our written instructions may lead to injury, violation of building codes and voiding the product warranty. For more information visit us at belcofp.com.

Best Practices – XT POST and XT TRIM

MOISTURE



- Keep XT Products stored flat in a clean dry environment. Do not install wet product.
- Keep installed XT Products away from continuous moisture sources and use proper flashing and moisture control techniques to minimize water intrusion.
- Avoid direct contact with stucco, brick or cultured stone.

SEAL



- SEAL ALL FIELD CUTS, with a premium 100% acrylic latex primer.
- Topcoat all exposed surfaces (including field cuts) within sixty (60) days of installation with two (2) coats of 100% acrylic latex exterior grade paint intended for wood per manufacturers' application instructions.
- XT POST - Holes that expose the conduit opening in XT POST must be flashed, and/or caulked to prevent moisture intrusion. Follow manufacturers' application instructions for best results.
- XT TRIM - A premium, flexible, paintable caulk is required at all joints and where XT TRIM abuts siding, windows and doors.

FASTEN



- Use ONLY corrosion resistant fasteners such as stainless steel or hot-dipped galvanized nails. Leave nails snug or flush with the surface. Do not use staples. Through-bolting is not permitted on structural XT POST connections.
- XT TRIM - Place fasteners no less than 1/2" from ends and edges of XT TRIM. Double nail the ends to structural framing members. For 6" wide boards, double nail along the length. For 4" and narrower boards, single nail along

CLEARANCES

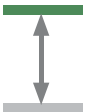

- Maintain 8" above finished grade. Maintain 1" clearance above concrete, flashing or any surface that may collect water.
- XT TRIM - Maintain a 3/16" expansion gap between butt joints and aforementioned abutments to allow for proper caulking per manufacturers' application instructions.

XT POST

STORAGE

XT POST must be stored flat, in a clean and dry environment (preferably on stringers in a warehouse or covered area) until the time of installation. Avoid any contact with the ground, concrete, or standing water.

Keep XT POST clean and dry. Inspect products prior to installation as installation of wet product may result in shrinkage. Belco Forest Products (“Belco”) IS NOT responsible for damage caused by improper storage, maintenance, or installation of XT POST.

WATER RUNOFF & MOISTURE CONTROL

Where XT POST is in close contact with concrete or soil, a post base MUST be used to raise the post a minimum of one (1) inch above concrete or eight (8) inches above the soil. XT POST must have a clearance of at least one (1) inch above any surface that may collect water; said surface must be sloped or otherwise designed for proper drainage so XT POST is not directly exposed to standing water.

The structure to which XT POST is applied should be well vented and dry. As with other wood products, XT POST must be kept free from excessive moisture. Exposure to constant sources of water (sprinklers, condensation), inadequate sealing or flashing, or failure to follow common building practices that prevent moisture intrusion, may cause damage to the product and affected products may not be covered by the warranty.

CUTTING & MACHINING

XT POST can be notched for use as a deck post. Cut notch using a circular saw and finish corners with a handsaw or jigsaw. Vertical cut length will vary depending on the depth of your deck framing. Typically, cut the notch so the bottom of the post stops 1/2” above the bottom above the bottom of the deck joist. If your deck is sloped, match the slope in the horizontal cut that will sit on top of your decking. Fasten per building codes.

ALL field cuts and machined products MUST be sealed with a premium, 100% acrylic primer and topcoated per finishing instructions. See *Finishing*.

BETTER: Treat with a suitable wood preservative end cut solution and topcoat per instructions found later in this document.

BEST: Treat with a suitable wood preservative end cut solution, and prime with a quality, 100% acrylic latex primer and topcoat per instructions. See *Finishing*.

FASTENING

DO NOT use staples. Use only corrosion resistant fasteners, such as stainless steel or hot-dipped galvanized nails, and install per hardware manufacturers’ recommendations.

It is recommended that all connector holes are pre-drilled. Pilot holes are required for lag screws, whose maximum permitted diameter is 1/2”. Through-bolting is NOT permitted on structural connections.

INSTALLING

Uplift Application

When XT POST has been designed for use in an uplift application, post bases and caps are REQUIRED. Belco recommends Simpson Strong Tie products but products of equal properties are accepted. Refer to base and cap manufacturer’s instructions for capacities and connector attachment.

Vertical Load Only Application

When ArmorPost has been designed for use in a vertical load only application, a nailed connection can be implemented.

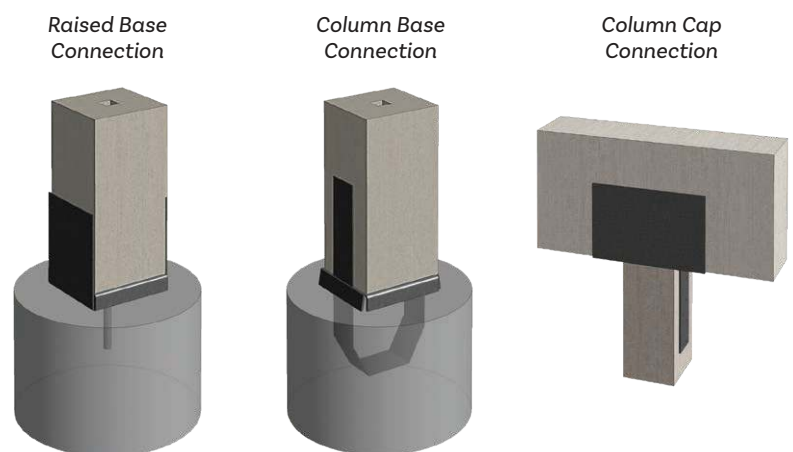

Accessory Holes

When XT POST is modified with the installation of lights or other accessories, holes sizes shall be limited to the following:

- 4x4: 5/8" diameter
- 6x6: 3/4" diameter
- 8x8: 3/4" diameter

Holes shall be centered on the post and spaced vertically, at least eight (8) inches apart for multiple holes. Holes other than those required for installation of approved post bases and caps are NOT permitted within eight (8) inches of the top or bottom of the post.

If holes expose the conduit opening in the center of XT POST, they must be flashed and/or caulked to prevent moisture from entering the space. For caulking, use an exterior quality, flexible, paintable caulk. Follow the caulk manufacturer's instructions for application. DO NOT use hard-setting caulk.

FINISHING

All exposed surfaces, including field cuts of XT POST MUST be topcoated with two (2) coats of quality, un-thinned, 100% acrylic latex, exterior grade paint intended for wood siding within sixty (60) days of installation.

Paint must be applied and maintained (including repainting) in strict accordance with the paint manufacturer's specifications.

Before painting, remove any dust, dirt, mildew or other debris by gently washing the XT POST surface with a brush, water and mild detergent. DO NOT use a pressure washer. Allow ample dry time for all XT POST products before painting.

Belco recommends satin/semi-gloss or full-gloss acrylic latex. DO NOT use stains, shake and shingle paints or vinyl based paints.

Belco does not warrant the performance of field applied finishes. Finish performance is dependent upon the quality and quantity of paint used, the methods under which it was applied, all of which are controlled by the paint manufacturer and applicator.

DESIGN VALUES FOR STRUCTURAL GLUED-LAMINATED SOFTWOOD TIMBER STRESSED PRIMARILY IN AXIAL TENSION OR COMPRESSION^(1,2,3)

Comb. Symbol	Species	Grade	Modulus of Elasticity E ⁽⁴⁾ 10 ⁶ psi	Compression Perpendicular to Grain F _{c⊥} psi	Axially Loaded			Bending About Y-Y Axis			Bending About X-X Axis		Fasteners	
					2 or More Lams F _t psi	Compression Parallel to Grain		Loaded Parallel to Wide Faces of Laminations			Loaded Perpendicular to Wide Faces of Laminations			Specific Gravity for Dowel-Type Fastener Design
						4 or More Lams F _c psi	2 or 3 Lams F _c psi	Bending			Shear Parallel to Grain	Shear Parallel to Grain		
								4 or More Lams F _{by} psi	3 Lams F _{by} psi	2 Lams F _{by} psi				
6	7	8	9	10	11	12	13	14	15					
Western Species														
EWS 22 ⁽⁹⁾	SW	L3	1.0	315	525	850	675	800	700	550	170	725	195	0.35

REFERENCE: APA Y117, Glulam Design Specification

XT TRIM

XT TRIM is a decorative, non-load bearing trim product. DO NOT use XT TRIM products to replace any structural components.

Failure to install XT TRIM in accordance with these written instructions may lead to injury, violation of building codes, and voiding of the product warranty.

STORAGE

To help minimize movement, allow XT TRIM to acclimate to local conditions prior to installation. XT TRIM must be stored flat, in a clean and dry environment (preferably on stringers in a warehouse or covered area) until the time of installation. Avoid any contact with the ground, concrete, or standing water. Avoid storage in the extreme sun or hot weather for prolonged periods of time.

Keep XT TRIM clean and dry. Inspect products prior to installation as installation of wet product may result in shrinkage. Belco Forest Products (“Belco”) IS NOT responsible for damage caused by improper storage, maintenance, or installation of XT TRIM.

WATER RUNOFF & MOISTURE CONTROL

A minimum of eight (8) inches MUST be kept between XT TRIM and finished grade. If applied adjacent to roofs, porches, patios, sidewalks, etc., XT TRIM must have a clearance of at least one (1) inch above any surface that may collect water; said surface must be sloped or otherwise designed for proper drainage so XT TRIM is not directly exposed to standing water.

The structure to which XT TRIM is applied should be well vented and dry. DO NOT install XT TRIM over soaked or buckled sheathing, or any other structure that has excessive moisture conditions.

As with other wood products, XT TRIM must be kept free from excessive moisture. Exposure to constant sources of water (i.e. – sprinklers, condensation), inadequate sealing or flashing, or failure to follow common building practices that prevent moisture intrusion, may cause damage to the product and affected products will not be covered by the warranty.

CUTTING & MACHINING

For the cleanest cut, a hand saw or power saw with a fine-tooth carbide tipped blade is recommended. The cutting action should be into the face of the material, positioned so dust will be blown away from the user and others in the working area.

For door and window openings, 45° diagonal cuts of trim ends are acceptable. If making scarf joints, cut on a 22.5° angle.

Some 1” XT TRIM products may have a wax coating on the ends of the board. Belco recommends cutting the ends and re-priming with 100% acrylic primer to ensure the topcoat adheres to the ends effectively.

XT TRIM can be mitered, ripped and/or routed for decorative applications. Machining depth should not exceed 5/16” for 1” products and 1/2” for 5/4” and 2” products. Machined products should not have any flat surfaces where water can accumulate. An angle of at least 100° from the vertical must be maintained to provide adequate drainage.

For end cuts and machined products, prime with a quality, 100% acrylic latex primer and topcoat per instructions. See *Finishing*.

BETTER: Treat with a suitable wood preservative end cut solution and topcoat per instructions. See *Finishing*.

BEST: Treat with a suitable wood preservative end cut solution, prime with a quality, 100% acrylic latex primer and topcoat per instructions. See *Finishing*.

CAULKING

Use an exterior grade, premium, flexible, paintable caulk. Follow the caulk manufacturer's instructions for application. DO NOT use hard-setting caulk. Caulk is required at all butt joints and scarf joints, and where XT TRIM abuts siding, windows, and doors.











FASTENING

DO NOT use staples. Use only corrosion resistant fasteners, such as stainless steel or hot-dipped galvanized nails (minimum 8d recommended). Fasteners must be long enough to penetrate the structural framing members a minimum of 1-1/4". Drive nails perpendicular to the framing and trim, leaving nails snug or flush with the XT TRIM surface. DO NOT overdrive or countersink the fasteners. If this happens, see chart for corrections.

All joints must fall on a structural framing member. Place fasteners no less than 1/2" away from the ends and edges of the XT TRIM. Both ends MUST be double nailed and additional fasteners must be spaced a maximum of twenty-four (24) inches on center, along the length of the board OR both ends double nailed and additional fasteners spaced a maximum of twelve (12) inches on center along alternating edges of the length of the board. If boards are eight (8) inches or wider, three (3) nails along the width of the board are required. For scarf joints, Belco recommends double nailing each end of each board but the double nailing of one end so it penetrates both pieces is acceptable.

For butt joints* and where the edges of XT TRIM abut siding, windows, and doors, leave a minimum of 3/16" space to allow for proper caulking.

**This may not apply to corners and window trim. See section entitled "Installing" for more information.*

Condition:		Correction:	
Snug		OK	
Flush		OK	
Visible fiber		Paint	
Countersunk, 1/16" - 1/8"		Apply caulk	
Countersunk, more than 1/8"		Apply caulk & re-nail	

INSTALLING

Horizontal Trim & Belly Band

Flashing is required over all horizontal trim. Belco recommends a sloped metal Z-flashing.

Batten

If using trim less than three (3) inches wide as battens, apply one nail per width, every twenty-four (24) inches. For all other widths, refer to instructions in the "Fastening" section.

When battens are applied over siding at vertical joints, sealant is not required. When applied to walls with horizontal joints, DO NOT run the battens over the joints and flashing. Horizontal band boards should be properly flashed above and below the board, with flashing installed below the board covering the top ends of the batten strips below. Leave a minimum 3/8" space between the end of the batten and the band board and DO NOT caulk.

Corners

XT TRIM width must extend beyond the face of the siding. Corner trim edge may lightly touch the adjacent trim edge. Caulking of the corner abutments is acceptable but not required.

Belco recommends installing XT TRIM directly to the structure but installing over the siding is acceptable. If using this method, the width of the trim must overlap the siding by a minimum of two (2) inches and caulking between trim and siding is not required.

If pre-assembling corners, cut XT TRIM pieces to size with clearance requirements in mind. Set pieces perpendicular and pre-drill fastening holes a minimum of twenty four (24) inches on center. Fasten with proper nails as outlined in the “Fastening” section.

Windows, Doors & Openings

Be sure to follow window and/or door manufacturers’ guidelines for trim installation. All openings must be properly sealed and properly flashed to avoid excess moisture. Trim ends may lightly touch adjacent trim edges around windows and doors only. Caulking of the window & door trim abutments is acceptable but not required.

For window sill, fasten one edge by nailing into the face of the product, where the material starts to bevel, at a diagonal into the framing member. Product should be single nailed at a maximum of sixteen (16) inches on center, alternating between the face of the board and coming up on the underside of the board.

Fascia & Rake

XT TRIM may be installed directly to rafter tails. If XT TRIM extends beyond the protection of the roof system, it may not be covered by the warranty. To minimize exposure to the elements, attach a metal coping to the XT Trim that is integrated with the roofing system. Install a drip edge to prevent water buildup behind the fascia and use gutters wherever possible. DO NOT attach gutters directly to XT TRIM.

At corners, all joints must be supported by framing and do not nail the face of one fascia member into the edge of another.

Mounting Blocks

XT Trim width must extend beyond the face of the siding. Prime and paint all cut ends, edges and holes. For onsite assembled blocks, use metal Z-flashing over the top side of mounting block. Leave a minimum 3/8” space above the flashing and DO NOT caulk. For pre-assembled blocks, leave proper spaces at the two sides and bottom. Caulk said spaces along with the mounting block cutout.

Adjoining Stucco, Brick or Cultured Stone

To avoid direct contact with stucco, brick or cultured stone, Belco recommends separating materials with a minimum 1/2” space and caulking. Refer to caulking and cladding manufacturer’s instructions for additional spacing and sealing requirements. Metal flashing, polyethylene film, felt or masonry standoffs may also be used. Apply sloped Z-flashing over the horizontal trim to redirect water to the outer surface of the wall.

FINISHING

All exposed surfaces, including field cuts of XT Trim MUST be topcoated with two (2) coats of quality, un-thinned, 100% acrylic latex, exterior grade paint intended for wood siding within sixty (60) days of installation.

Paint must be applied and maintained (including repainting) in strict accordance with the paint manufacturer’s specifications.

Before painting, remove any dust, dirt, mildew or other debris by gently washing the XT TRIM surface with a brush, water and mild detergent. DO NOT use a pressure washer. Allow ample dry time for all XT TRIM products before painting.

Belco recommends satin/semi-gloss or full-gloss acrylic latex. DO NOT use stains, shake and shingle paints or vinyl based paints.

Belco does not warrant the performance of field applied finishes. Finish performance is dependent upon the quality of paint used, quantity of paint used and the methods under which it was applied, all of which are controlled by the paint manufacturer and applicator.

*Look for the mark where the
treatment comes standard.*



BELCO 